

Review on the most popular anaerobic digester models in the Mekong Delta

Các kiểu hầm ủ khí sinh học phổ biến ở ĐBSCL

Review paper

Nguyen, Vo Chau Ngan*; Phan, Trung Hieu; Vo, Hoang Nam

Department of Environmental Engineering, College of Environment and Natural Resources, Can Tho University, Can Tho City, Viet Nam

In Vietnam, the research and application of biogas technology were given a considerable attention in past 30 years. There is several biogas plant models apply in the suburban and rural areas where most people's life is based on animal husbandry. Each biogas plant model own strong points or weakness that adapt to detail circumstances. The biogas plants play a key role within the VACB farming system especially in the Mekong Delta where produce more than 50% of yearly national agriculture production. This paper gives a comprehensive overview on the popular biogas models in the Mekong Delta through its development history. Knowing on the presented biogas technology in the Mekong Delta will lead the biogas-related organizations or private on biogas development at this region.

Ở Việt Nam việc nghiên cứu và ứng dụng công nghệ khí sinh học đã được chú ý trong 30 năm gần đây. Một số mô hình khí sinh học đã và đang được lắp đặt tại các vùng ngoại ô và nông thôn là những nơi tập trung nhiều hộ dân chăn nuôi heo. Có nhiều mô hình khí sinh học đã được triển khai, trong đó mỗi mô hình đều có những điểm mạnh và điểm yếu đáp ứng theo từng yêu cầu cụ thể. Ở ĐBSCL nơi sản xuất trên 50% sản lượng nông nghiệp của cả nước, hầm ủ khí sinh học đóng một vai trò quan trọng trong mô hình canh tác VACB. Bài báo này trình bày chi tiết các kiểu hầm ủ khí sinh học phổ biến tại ĐBSCL tương ứng với từng thời điểm phát triển của công nghệ này. Sự hiểu biết về các kiểu hầm ủ khí sinh học hiện tại ở ĐBSCL sẽ giúp các tổ chức hoặc cá nhân có liên quan trong việc định hướng phát triển công nghệ khí sinh học cho toàn vùng.

Keywords: anaerobic digesters, anaerobic process, Mekong Delta, VACB farming system

1. Introduction

According to Do (2005), Nguyen and Nguyen (2005), researches on biogas technology started from decade '60 of the last century in the Mekong Delta (MD). However, the research and application of biogas technology were given a considerable attention in the past 30 years. Since 1990, the biogas technology was strongly developed both in quality and in quantity.

Following the development history of the biogas plants (Nguyen, 2011), and based on the considerable large number of the biogas plants constructed in the MD, the biogas plants applicable in the MD can be distinguish by appearing milestones as in Figure 1.

Reviewing the popular biogas plants is to get in-depth knowledge on biogas technology that is applied in the

MD. This understanding is necessary for the development of biogas sector in the future.

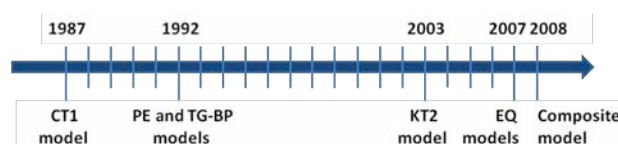

Figure 1. The milestones of popular biogas plants in the MD

2. The popular biogas plant models

2.1 The CT1 model

Since 1987, the Renewable Energy Center (REC) in Can Tho University designed and introduced the CT1 biogas plant model (Figure 2). The CT1 plant was an upgrade

* Corresponding author
E-mail: nvcngan@ctu.edu.vn

model of the fixed-dome plant in cylinder shape with two separate parts - the digester part in fixed volume of 3.2 m³ and the gas-holder part of 700 ÷ 800 L. Both the digester and the gasholder were made by ferro-cement pre-manufactured at the factory and then transported to the installation sites. A circular pit is dug in a convenient place at the farmer's yard to install the digester. The soil is removed out at one side of the pit for slanting outlet pipes. A vertical inlet pipe is installed through the gasholder with the upper end connected to a feeding cone, the lower end put underneath the dung slurry to ensure no gas release through this pipe. In this model, the whole digester and part of the gasholder are underground to maintain the dung slurry in good degradable conditions.

A gasholder unit of 1.3 m diameter and 0.58 m height is installed right above the gasholder ring that is round-fixed into the inner wall of the digester. By handmade works, this module takes lot of labor time and its thickness bigger than 0.02 m makes the transport difficult due to its weight. To avoid the gasholder floating up, three gasholder stoppers are installed inside of the digester body. These gas-holder-stop units keep the gasholder from moving on vertical direction and always submerged into the water layer so that biogas cannot be released from the gasholder. A gas vent of 0.021 m diameter is fitted on the top of the gasholder unit to collect gas for the gas appliances.

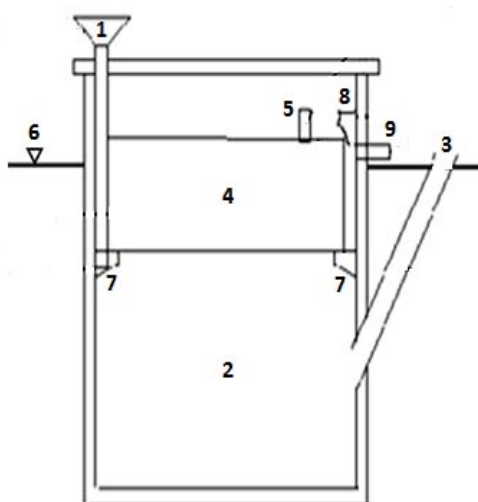

Figure 2. The CT1 biogas plant
 1 - Inlet pipe; 2 - Digester; 3 - Outlet pipe; 4 - Gas-holder; 5 - Gas vent; 6 - Ground level; 7 - Gas-holder ring; 8 - Gas-holder stop; 9 - Discharge pipe
 (Source: Le, 2005)

The advantages of this model:

- It takes less time (2 ÷ 3 days) to install the plant since all components are prefabricated.

The disadvantages of this model:

- Input material must be collected and fed by hand.
- Prefabricated components are bulky, causing an obstruction for transportation from factory to households.

The lifetime of the CT1 plant is estimated at about 10 years, but due to its disadvantages and the availability of some alternative biogas models, this plant is not considered attractive anymore. By 1995, more than one hundred units were already constructed but the REC stopped manufacturing this biogas model (Le, 2005).

2.2 The PE model

This digester is made of a tube-like plastic digester bag in which the gas is stored at the upper part. The inlet and the outlet are attached directly to the membrane of the tube. The model, a continuous-flow flexible tube, was firstly introduced in Taiwan, where it was manufactured using material from the red-mud PVC (Bui, 1996, cited from Pound, 1981). Later on, this model has been simplified by Preston and co-workers, first in Ethiopia, then in Columbia (Bui, 1996, cited from Botero, 1987). Since 1992, within the project supported by FAO and SIDA, the College of Agriculture and Forestry in Ho Chi Minh City introduced the polyethylene (PE) tube biogas digesters (Bui, 1994). By low cost and simplicity of installation, this model has been rapidly adopted and disseminated by the network of Agricultural and Forestry Extension, VACVINA and some local private activists (Le, 2008).

In the MD, the PE digester is fabricated from transparent tubular polyethylene tubes of 0.16 mm thickness with a diameter from 0.8 to 1.4 m. The digester is made by overlapping three layers of PE tube together to enhance safety capacity of the PE layers. The length of a digester could be up to 12.0 m depending on the number of pig herds (Figure 3). To install the inlet and outlet pipes, one 0.15 m diameter pipe (ceramic or PVC) is inserted to one half of its length to either one of the two open ends of the PE tube and the PE tube is folded around it. The joint is wrapped tightly with a rubber band similar to the inner tube of bicycles. A PVC pipe of 0.021 m diameter is fixed at one position on the upper surface of the digester bag and it is used as a gas vent. All the joints must be completely airtight. The digester is placed in a horizontal ditch with a slight slope from the inlet to outlet pipe. Three quarters of the digester's volume are filled with animal dung slurry through the inlet pipe and one-quarter is reserved for exhaust. Biogas is accumulated at the upper exhausting space of the digester and is flowing up through the gas vent into one separate gasholder unit (Figure 4). To fabricate the gasholder bag, two PE tubes are inserted inside each other so that the outside layer can protect the inside layer. The length of the gasholder can be up to 6.0 m long according to the digester volume.

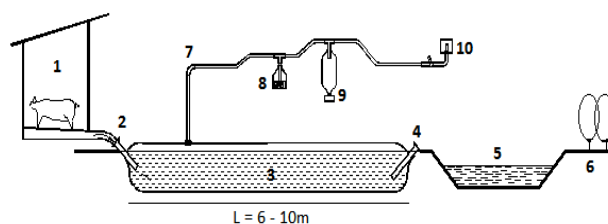

Figure 3. The PE digester
 1 - Pig-pen; 2 - Inlet pipe; 3 - Digester; 4 - Outlet pipe; 5 - Discharge pond; 6 - Garden; 7 - Gas vent; 8 - Security valve; 9 - PE gas-holder; 10 - Stove
 (Author: Vo, H. N.)

Between the digester and the gas-holder bag is a safety water seal through which the biogas escapes if too much pressure is built up within the digester. To make this water seal, the farmer needs a 2-liter transparent plastic bottle (the used water bottle or the used cooking-oil bottle, etc.) filled with water. The farmer inserts a T-pipe into the bottle that will be submerged about $8 \div 10$ cm under water. For this T-pipe, one side is connected to the inlet gas pipe coming from the digester, while another side is connected to the outlet gas pipe that leads to the biogas appliance. When biogas is produced in excess in the digester, a high-pressure will force the water in the safety water seal to empty the water inside the bottle. As a re-

sult, this action helps to release the extra biogas that maintains the stable pressure inside the digester and prevent the digester from being broken due to a high pressure.

As for the biogas filter, almost none of the farmers in the MD installed this unit into their biogas plants. The reason for this is the fact that the biogas is mainly used for cooking so that the farmers do not care of the negative effects of some chemical components (H_2S , CO_2) into their cooking tools.



Figure 4. The digester body (left) and the gas-storage (right) of the PE model

The advantages of this model:

- Low cost, easy to install.
- The fermentation slurry is agitated slightly by the movement of the digester body and the continuous-flow inside the digester.
- Sufficient in the MD where the groundwater table is high.

The disadvantages of this plant:

- The PE layer is very sensitive to the sunlight, falling objects, people and animals so that they have short life-time and can be easily damaged.
- In case the sediment is accumulated in large amounts inside the digester, it is difficult to remove it.
- By installation on the ground, the temperature inside the digester is unstable for decomposition process.
- This channel-type digester takes more land area.
- The produced biogas needs to be stored in a plastic bag separated from the digester body and it is not safe for this bag to be installed nearby a kitchen.

- By storing the gas in a plastic bag, it has a rather low pressure (around 10 hPa) that only suitable to supply gas for cooking and not for lighting.

2.3 The TG-BP model

This biogas plant was tested and introduced broadly in the southern part of Vietnam from 1992 by REC. The TG-BP plant was developed within the Thailand-German Biogas Program from 1988 \div 1995 in cooperation with the scientists from Germany (GTZ), and Thailand (Chiang Mai University and Department of Agricultural Extension). Up to now, there are about 3,000 units constructed in the MD, of which about 1,000 units installed in Sa Dec town - Dong Thap province and the rest built in other provinces such as Can Tho, Vinh Long, An Giang, Bac Lieu, etc. (Nguyen and Do, 2009).

There are three main components continuously connecting on this model: (i) the inlet tank where pig manure is mixed with water before it is discharged into digester; (ii) the digester where the mixture of pig manure and water is fermented to produce methane and other gases; and (iii) the compensating tank which collects excess slurry effluent from the digester. These components act as a dynamic system. When gas is produced inside the digester, the gas pressure will push manure and slurry at the bottom of the digester to flow up into compensating tank. When this gas is consumed, the slurry in the compensating tank will flow back into the digester to push the gas up for usage (Figure 5).

The digester is formed by a dome chamber made from solid bricks and mortar on surface of a concrete footing-beam. A circular pit is dug into a depth base on farmer's yard. After the excavation is complete, the ground-soil has to be compacted. In the MD, due to the soft ground-soil and high groundwater table, piles are required at the foundation in case big biogas plants with volumes bigger than 18 m³. Due to its big weight, combined to big volume of liquid stored, the digester will be easily sinking if any crack appears in the foundation.

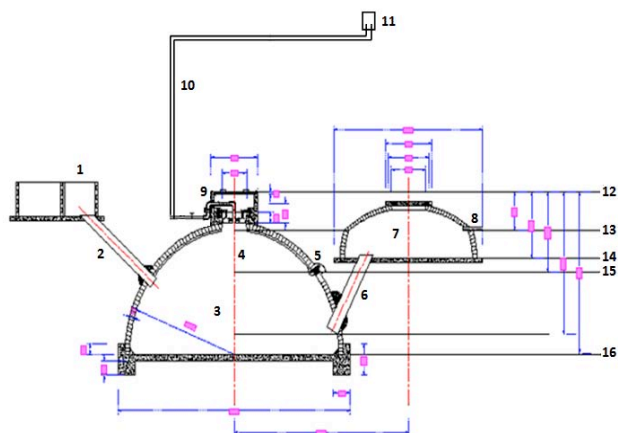

Figure 5. The sketch of TG-BP biogas plant
 1 - Inlet tank; 2 - Inlet pipe; 3 - Digester; 4 - Fixed-dome gas-holder; 5 - Safety belts system; 6 - Outlet pipe; 7 - Compensating tank; 8 - Discharge pipe; 9 - Entry hose with gas-light seal; 10 - Gas pipe; 11 - Stove; 12 - Digester top level; 13 - Ground level; 14 - Zero line; 15 - Security belts level; 16 - Digester bottom level
 (Source: modified from CENREs, 2002)

The soil pit is cut out from both sides for inlet and outlet pipes. The mortar (one part cement and two parts sand) is spread over the surface of a brick ball layer (0.15 m thick) and compressed with a suitable quantity of water for making the foundations. A circular digester is constructed on the foundation by raising a brick wall of 0.1 m thick. For the brickwork, the radius stick must be used with each layer of brick to keep the digester radius constant. This procedure is slow since the brickwork must get dry in order to avoid cracks in the wall.

An inlet pipe 0.16 ÷ 0.21 m diameter made by PVC or cement is fixed in a slanting position with its lower end fitted in the digester wall above the foundation level. The upper end connects to the bottom of the inlet tank, which is normally connected to livestock pen. An outlet pipe of 0.16 ÷ 0.21 m diameter is fixed to the opposite side with the inlet pipe. To notice that the outlet pipe diameter has to be larger than the inlet pipe diameter so that the excess slurry could easily flow up to the compensating tank. In addition, the bottom edge level of the outlet pipe at the digester body should be lower than the bottom edge level of the inlet pipe that drains out the slurry at the bottom of the digester.

To avoid cracks on the digester body, two safety belts are attached on the digester wall: the soft belt and the hard belt. These belts are rather innovative when comparing to previous fixed-dome digesters. The soft belt is constructed to separate the bottom wall and the upper part of the

dome. In case the ground is sinking or the wall is cracked, this soft belt will prevent the vertical crack spreading up to the top of the dome. The soft belt is a flexible layer and is installed by placing bricks to form a wall outside the radius. The distance between the wall and the soft belt is one brick wide. The soft belt is built from 2 ÷ 5 layers of solid bricks, the bonding slurry is a mixing ratio of one part cement, three parts lime and 15 parts fine sand.

The produced gas is stored inside the fixed-dome of the digester. This fixed-dome is located at the top of the digester and is separated from the lower wall by the soft belt. The fixed-dome is constructed from solid bricks by casting one layer of vertical bricks on top of the soft belt. On each layer, the lower part of brick sticks out 3 ÷ 5 cm towards the inner of the dome. The brickwork will continue until the top of fixed-dome is 0.38 ÷ 0.39 m wide. Three layers of mortar will plaster the inner of this fixed-dome. Each of the mortar layers is 1 cm thick and is made of mixed materials as following (i) the first layer by the mixture of 1 part cement : 1/3 parts lime : 2.5 parts fine sand, (ii) the second layer by mixing 1 part cement : 1/4 parts lime : 2.5 parts fine sand, and (iii) the third layer by mixing 1 part cement : 1/4 parts lime : 2.5 parts fine sand. These special mortar layers help to prevent the gas leakage through the fixed-dome. In additional, the mixture of 1 part cement : 1/3 parts lime : 2.5 parts coarse sand is required to plaster the outer wall until the thickness of 3 cm is reached.

The hard belt is the beam of the fixed-dome. The required strength of the hard belt is obtained by the mixing 1 part cement : 2 parts fine sand : 4 parts stones (stone size of 1 ÷ 2 cm). This hard belt is formed of poured cement that covers the vertical bricks in a shape of mount (Figure 6).

The opening (0.38 ÷ 0.39 m diameter) at the top of the digester is used for maintenance works. Nevertheless, to ensure for airtight conditions, a digester neck is built to support the lid. The digester neck is made of solid bricks and plastered mortar installed right on top of the digester opening to form a round-ring. A gas outlet valve (0.021 m diameter) is fixed on the lid of the dome.

The volume of gasholder takes about 1/3 of the total digester volume. When the gas production commences, the slurry is displaced into the compensating tank through the outlet pipe. However, when the gas is consumed, the slurry flows back from the compensating tank into the digester, breaking the scum at the surface of slurry inside the digester. The compensating tank's dimension is according to the dimension of the digester with the volume of about 1/6 ÷ 1/8 of the digester volume. To build the compensating tank, the masons prepare a foundation at the zero line height level that must be at the same level as the lowest level of the slurry inside the digester. The foundation is constructed by a 5 cm concrete layer obtained by mixing 1 part cement : 2 parts fine sand : 4 parts stones (stone size of 1 ÷ 2 cm).

The digester body is built completely underground while the digester neck is rising above ground level. Also the compensating tank is buried underground, too. This soil cover helps to avoid any cracks and to let the weight of

soil support against the uplift pressure of groundwater on the dome foundation. Vegetables can be planted on the

top to prevent soil erosion.

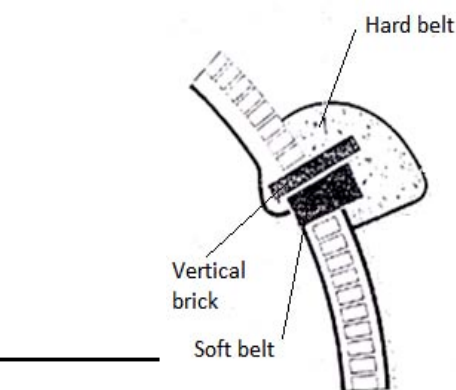

Figure 6. The construction of the belts (left) and the safety belts package (right)
(Source: CENREs, 2002)



Figure 7. The construction works on TG-BP plant
(Source: CENREs, 2002)

The advantages of this plant:

- The long lifetime (the mason already offer at least one-year warranty to this plant model).
- The digester installed in form of semi spherical dome helps to eliminate construction failures while a digester constructed in rectangular form can lead to cracks at its corners.
- The safety belts package eliminates the failure of digester body.
- Construction with available materials those are easy to find locally.
- Saving land area due since the tanks are constructed almost completely underground.
- Less maintenance works and equipment replacement since the plant has less mobile equipment and no rusting steel parts.

- The fixed-dome leads to high pressure of biogas (40 to 60 cm of water column), which enables the biogas to be used as a substitute for solid/liquid fuels in cooking and lighting.
- Due to underground construction, the slurry ferment is in stable conditions even in low temperature.

The disadvantages of this model:

- The investment cost is high.
- Requires skilled masons and needs supervision by experienced biogas technicians.
- Unstable fermentation process due to changes on slurry level through the outlet pipe. When biogas is in use, the slurry containing oxygen from the compensating tank flows back into the digester causing damage to anaerobic process. Due to this weakness, the TG-BP model mainly applies for small volume of digesters.

2.4 The KT2 model

The KT2 model is a further development version of the TG-BP model (Biogas project division, 2006) but without installation of the security belts package as the TG-BP model. The KT2 model is developed within the project “Vietnam Biogas Program for the Animal Husbandry Sector”. This project is presided by the Department of Livestock Production - Vietnam’s Ministry of Agriculture and Rural Development in cooperation to the Netherlands Development Organization (SNV). Based on this national project, there are more than 50,000 KT2 plants constructed in Vietnam (Tran, 2009). In the MD, about 7,254 units were installed at September 2010 (Le, 2010).

The characteristic of this model is the semi spherical dome on top of the plate bottom, which makes the plant more resistant against the upward forces typically connected with high groundwater levels. The plant is, therefore, particularly suitable for the MD where the groundwater level is high (Figure 8).

The advantages of this biogas plant are, besides its strengths as mentioned in previous version (TG-BP model), the low investment cost comparing to TG-BP model due to its simple construction method on:

- No security belts system.
- The digester is installed on a concrete floor without footing, which is required in TG-BP plant.
- Is not using special mixing of materials like cement, sand and lime as required in TG-BP plant.

The disadvantages of this model:

- The lifetime of the KT2 model is presumed to be not as long as the lifetime of the TG-BP model.
- The mixing ratio water : pig manure is only from 1 : 1 to 1 : 2, which affects the treatment efficiency of the system.

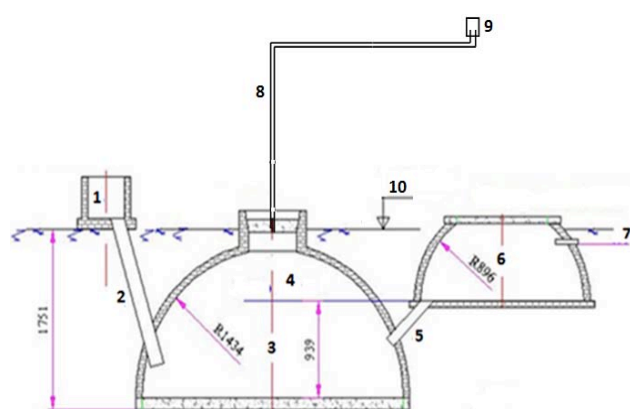

Figure 8. The KT2 domestic biogas plant
 1 - Inlet tank; 2 - Inlet pipe; 3 - Digester; 4 - Fixed-dome gas holder; 5 - Outlet pipe; 6 - Compensating tank; 7 - Over-flow level; 8 - Gas pipe; 9 - Stove; 10 - Ground level
 (Source: modified from Biogas project division, 2008)

The volume of this digester is defined based on quantity of input material, dilute ratio of pig manure and water, needed volume of biogas, etc. Following the designed volumes of digester of 2, 3, 4, 5, 6, 8 and 10 m³, the fixed livestock waste input to the digester will be of 50, 75, 100, 125, 150, 200, 250 and 300 kg per day.

2.5 The EQ models

The biogas plant models of EQ1 and EQ2 were developed by scientists from Can Tho University within the project “VIE020 - Water hyacinth” since 2008 (Nguyen and Do, 2009). These models represent an improvement and combination of the TG-BP and the tube shape models. Biogas produced from a digester is stored in a PE bag for gas appliances.

According to the project framework, the EQ1 and EQ2 models are mainly installed in Hau Giang province, where the project is implemented. After termination of the project, there have been about 75 units of both EQ1 and EQ2 built within the project in Hau Giang province and even more plants in other provinces of the MD.

For the EQ1 plant, its digester body is similar to the TG-BP digester. Nevertheless, to save the cost of fixed-dome constructed by some special ways (plastering three mortar layers, preparing mortar with cement, sand, and lime), there is a HDPE circular cover layer fixed at the opening of the digester. Moreover, this plant is made of air-bricks (size of 8 × 8 × 18 cm), saving the construction time and the labor cost. The biogas produced from fermentation process flows up to the gasholder occupying about 1/5 ÷ 1/6 of the total digester volume. Then the biogas obtained moves out to a separate PE gas storage bag through a gas vent (0.021 m diameter), which directly connects into the HDPE cover layer. In addition, this EQ1 model includes no compensating tank so that the outlet slurry discharges directly into open-air place (Figure 9).

For the EQ2 model, the digester body seems to be similar to the digester body of EQ1 model. However, there is a closed fixed-dome installed on the top of the digester instead of the HDPE cover layer as installed in EQ1 model. At this closed fixed-dome, there is a crank handle hanging right at the top center and a gas pipe installed nearby. The crank handle is installed to diversity input materials. Farmers can apply some kind of biomass into the digester and then use this crank handle to breakdown the thick scum. This EQ2 model is also a replacement of the compensating tank with an open chamber with big hatch applicable for maintenance works (Figure 10).

The advantages of the EQ1 and EQ2 models:

- These models have separate gas storage bag so that the gasholder volume inside the digester only takes about 1/5 ÷ 1/6 of the total volume of the digester while the gasholder volume is 30 ÷ 40% of the total digester volume in TG-BP and KT2 models. As such, we can, in case of EQ models, save the labor cost and the materials cost.

- Saving construction time and labor cost due to the digester made of air-bricks (size of $8 \times 8 \times 18$ cm compared to $4 \times 8 \times 18$ cm of the solid bricks).
- Due to the crank handle installed to the EQ2 model, we can diversify the input materials into the digester. Furthermore, it is more convenient for maintenance work through a big hatch connecting to the digester and the open chamber.
- There is no requirement of skilled masons because these models do not require three mortar layers of cement, sand and lime, so that the local masons are often qualified enough to build these biogas models.

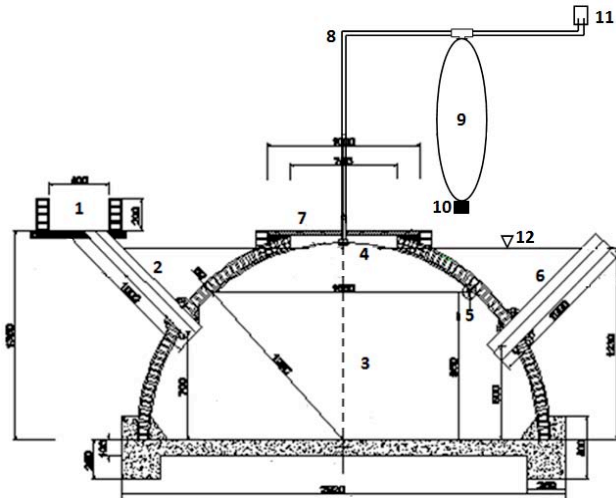

Figure 9. The EQ1 biogas plant

1 - Inlet pit; 2 - Inlet pipe; 3 - Digester; 4 - Gas-holder by HDPE layer; 5 - HDPE hanger; 6 - Outlet pipe; 7 - Cover plate; 8 - Gas pipe; 9 - PE gas-holder; 10 - Weight; 11 - Stove; 12 - Ground level

(Source: modified from Nguyen and Do, 2009)

The disadvantages of the EQ1 and EQ2 models:

- A short lifetime of the HDPE cover layer of the EQ1 plants. In addition, in case there is any block inside the EQ1 digester, farmers must drill a hole on the digester body for maintenance works.

Regarding the separate gas storage PE bag in both EQ1 and EQ2 models, it is highly risky to keep this bag nearby the kitchen. Moreover, the gas pressure (from $5 \div 10$ cm of water column) is high just enough for cooking, but not for lighting.

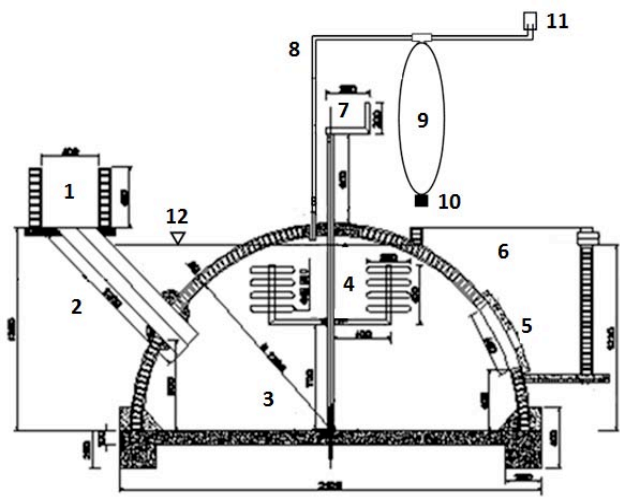

Figure 10. The EQ2 biogas plant

1 - Inlet pit; 2 - Inlet pipe; 3 - Digester; 4 - Stirring blades; 5 - Discharge hatch cover; 6 - Outlet pit; 7 - Crank handle; 8 - Gas pipe; 9 - PE gas-holder; 10 - Weight; 11 - Stove; 12 - Ground level

(Source: modified from Nguyen and Do, 2009)



Figure 11. The HDPE top-layer with gas collection point (left) and the completed EQ1 plant with protect box and gas pipe (right)

(Source: Nguyen and Do, 2009)



Figure 12. The completed EQ2 biogas plant with fulfilled outlet pit (left) and the crank handle installed inside digester with two blades (right)
(Source: Nguyen and Do, 2009)

2.6 The composite model

Composite plant is originated from China, being introduced to Vietnam since 2008. At present, this model has been manufactured by national companies. The biogas digester is made of synthetic material such as fiberglass, carbon fiber and polyester, which are 100% imported.

The composite model has two parts: the digestion part and the gas storage part, which is designed in one block and buried underground. In addition, the plant contains a fixed inlet for feeding material with the diameter of 800 mm and a fixed outlet of 900 mm diameter (Figure 13).

Feeding materials are fed through inlet pipe until reaching the level of 60 cm height of the inlet pipe (and also the outlet pipe). At this time, the gas pressure in the digester is zero ($P = 0$). After feeding, the inlet is close. The gas produced is stored in the upper part of the digester, and then it is pushed through gas pipe located in the middle point of the upper dome.

The digestion fluid is pushed through the outlet pipe. When the gas is used up, the gas pressure in gas section is 0. The biogas plant comes back to starting state. During the operation of fixed dome biogas plant, the substrate is moving up and down. The surface of the digestion solution narrows when is up and expands when it is down, which it will help reducing the formation of scum.

The advantages of this model:

- This plant is gas-tight, watertight and has high gas-pressure (up to 150 hPa), which makes possible the application of biogas for lighting.
- Saves construction area since the plant is buried underground, suitable to weak soil.
- Saves time for installation, does not need trained masons because the composite installation was implemented by technician of suppliers.
- It can be moved to another location when necessary.
- Simple operation and maintenance works.

The disadvantages of this model:

- The big barrier implies high investment costs.
- It has big components that are difficult to transport to installation sites.
- Is only available in few digester volumes so that not many choices are available for the users.

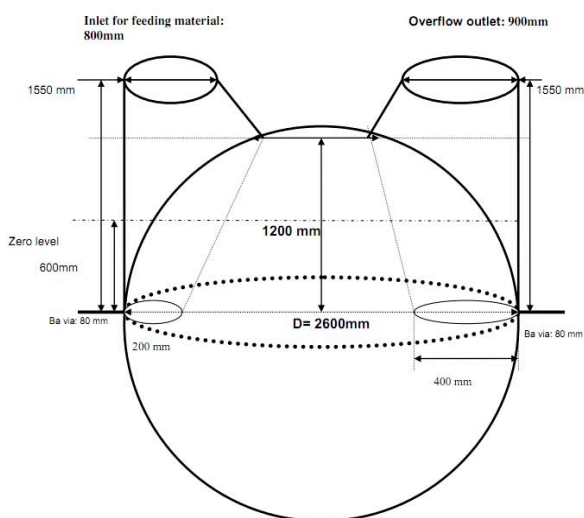

Figure 13. The composite plant
(Source: SEDDC, 2010)

This biogas plant was applied mostly in the northern and central part of Vietnam with more than 10,000 units (SEDCC, 2011).



Figure 14. Installation of the composite digester (left) and after soil filled (right)
(Photographer: Vo H. N.)

2.7 The improved rectangular parallelepiped plant

This plant is an upgraded version of the rectangular parallelepiped biogas plant developed by the Department of Agricultural and Rural Development in Soc Trang province (Le, 2005b). This model is mainly installed in Soc Trang province with more than 200 units (Figure 15).

The main improvement of this plant is that the inner side of the digester's top slab is covered by a PE layer. This PE layer helps increasing the airtight strength of the digester if any failure happens on the digester body.

This plant saves land area due to the digester being built right under a pigpen. The dimension of the digester is about 1.6 ÷ 2.0 m high, 2.0 m wide, and 3.5 m long. After the process of fermentation, the produced gas flows up to a separate gas storage bag. This bag is made of PE in 5 m length.

The advantages of this plant:

- The local masons are often qualified enough to build these biogas models.
- Easy to construct.
- Saves land area due to the digester being built under the pigpen.
- The leakage of the produced biogas through the cracks at digester corners is limited.

The disadvantages of this model:

- Low gas pressure in comparison to the semi sphere plants.
- Installation under the pigpen makes it difficult for maintenance works.

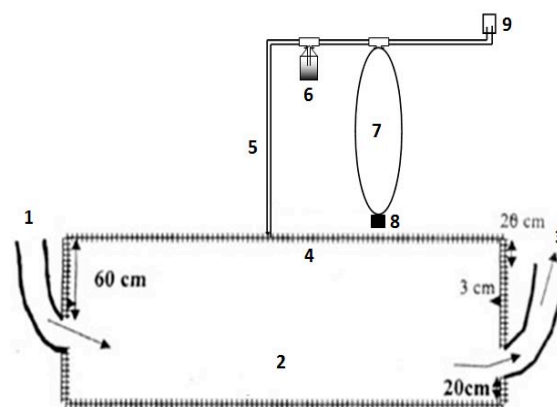

Figure 15. The improved rectangular parallelepiped biogas plant

1 - Inlet pipe; 2 - Digester; 3 - Outlet pipe; 4 - PE layer; 5 - Gas pipe; 6 - Security valve; 7 - Gas storage; 8 - Weight; 9 - Stove
(Source: modified from Le, 2005b)

3. A comparison of the popular biogas plants

In the MD, there are 6 presented popular biogas plants: PE, TG-BP, KT2, EQ1, EQ2 and composite plants. Each of popular models has strengths and weaknesses in the construction, operation, and maintenance processes. The choice of a biogas plant model depends on the support projects, the local authority impacts, the economic condition of farmers, etc.

An evaluation on these popular biogas plants in terms of their technical and economic aspects as described in the Table 1.

In 2002, the Ministry of Agriculture and Rural Development issued the Decision 21/2002/QĐ-BNN regarding the Vietnamese standards on environmental issues. The law includes 8 standards on a small size biogas plant (volume ≤ 10 m³). Some important issues are the hydraulic retention time (HRT) from 40 to 60 days (refer to 10TCN 492-2002), the diluted ratio of pig manure and water from 1 : 1 to 1 : 3, and the gas pressure up to 100 cm of water column (refer to 10TCN 496-2002).

Table 1. The detailed technical and economic parameters of the popular biogas plants

	PE	TG-BP	KT2	EQ1	EQ2	Composite
Input materials	Pig manure	Pig manure	Pig manure	Pig manure	Pig manure Other feeds	Pig manure
Hydraulic retention time (day)	17	20	30 ÷ 40	20	20	10 ¹
Dilution ratio pig manure : water	1 : 5	1 : 5	1 : 1 / 1 : 2	1 : 5	1 : 5	1 : 1.5 ¹
Gas stored rate (-)	1/3	1/3	1/2.5	1/5 ÷ 1/6	1/5 ÷ 1/6	1/3 ÷ 1/6
Gas pressure (cm of water column)	10 ÷ 20	40 ÷ 60	60 ÷ 80	10 ÷ 20	10 ÷ 20	160
The maximum pig manure input (kg/m ³ × day ⁻¹)	6.86	5.56	11.5 / 8.5	6.67	6.67	NA
Life-time (year)	NA	20	20	10	15	20
Installation time (day)	1	5	5	4	4	2
Cost estimate ² (VND/m ³) (US\$/m ³)	310,840 14.80	1,277,800 60.85	1,279,113 60.91	1,032,489 49.17	1,329,250 63.30	2,613,333 124.44

¹: parameters calculated base on the plant of 1.9 m diameter

²: this cost is based on the construction unit price in Can Tho city in September 2010

NA: not available

Comparing these standards to the technical parameters of the popular biogas plants in the MD, there are some identifiers:

- The HRT of wastewater in the composite plant is shortest comparing to other plants. Inside the composite plant, the HRT of substrate is only 10 days compare to other plants from 17 to 20 days (except the KT2 model has HRT up to 30 to 40 days). The lower HRT, the lower of treatment efficiency.
- High gas pressure inside the digester is good, which means that the biogas can be used for other purposes besides cooking but not higher than 60 cm of water column. According to the survey of SEDDC (2010), when the gas is used up completely from the composite plant, digestion solution in digester can go to the gas pipe causing stuck in the gas pipe. This situation is sometimes found in the KT2 plant, too.
- The models with separated gas-storage such as PE, EQ1 and EQ2 have low gas pressure and do not support farmers to apply the produced gas for lighting purpose. This is a weakness point of these models since the most of the rural areas in the MD lack electricity supply, especially in dry season.

Besides that, the EQ2 model with an innovation on crank handle is the sole model accepts multi-feeding materials. It is a strong point due to the insufficiency of pig manure that feeds into the biogas plant in the MD. In fact, pig manure as main feeding material for the biogas plant accounts for more than 90% (Tran et al., 2009). However, the pig market is unstable concerning the pig diseases, the high costs of pig feed or the low price of pork meat, etc. Thus, multi-feeding materials for biogas plant may represent an optimal solution.

Looking to the investment cost for each digester, this is one important factor that makes the farmers agree or not to installing a biogas plant. In the MD, the PE digester has the lowest investment costs but also one of the shortest lifetime spans. In comparison, other concrete plants need

higher investment costs (from 5 to 6 times higher). The composite plant has the highest investment cost. We could say, the investment cost is the biggest barrier on the development of biogas in the MD.

4. Conclusions

Some of biogas plant models have been already constructed in the MD such as the PE model, TG-BP model, KT2 model, EQ1 and EQ2 models, and the composite model. However, the dissemination of these models mostly depends on the biogas projects supported by some national or international agencies. The choice of biogas plant models applicable for the project areas is according to the project decision and each project normally chooses only one model of biogas plants to implement at the project area. This leads to a limitation in disseminating the biogas application benefits at larger scale in these regions. The reason for this is that, in case the farmers who are not beneficiaries from the projects but want to build a biogas plant cannot afford the biogas plant model that is selected by the project, these farmers have no alternatives for similar biogas plant models. It should be a good option for a biogas project to introduce some of other biogas models suitable and affordable for the local conditions to help the local farmers have more opportunities in approaching the biogas technology. This introduction could offer some low-cost models to attract more farmers to apply the biogas plant besides the actual biogas plant models applicable to the project area. By this way, biogas plants will be beneficiary to a larger number of local farmers as well as to the protection of the total local environment.

In conclusion, there seems to be no “best choice” biogas plant model for all the farmers in the MD. The existing models available in the MD have their own strengths and weaknesses. For example, TG-BP model has a long life-time and good operation but high investment cost while PE tube model has low investment cost but unstable operation and a short life-time. More studies are required to search for new optimal biogas models to the real situation of the MD of Vietnam. Such future biogas plant models should take three requirements into account including

efficiency, economic, and large-scale application of the model when being designed for the MD. It is also worth of notice that most of the local people in the rural areas of the MD where biogas plants are in need are poor and low education. Cost saving is still a guiding principle in designing a biogas plant model that is applicable for the MD. Only by using cheap and available local materials, the low-cost biogas plant could apply at large scale in the MD. Moreover, a biogas plant should be simple in construction, operation, and maintenance. In respect of the diverse biogas usage and application, the gas pressure from the plant should be high enough for not only cooking but also lighting, and introduction of different models for different situations to give more alternatives for biogas application to the local people.

There is a limitation in information channels to introduce biogas technology at the rural areas. In case of no biogas plant installation, almost livestock waste discharges freely into open-air without any waste treatment methods. This causes more pollution on the open water source in the local areas that is used by most of the local people, especially the poor, for their living. Therefore, it is necessary to announce more communication programs on biogas technology, water and sanitation, etc. to rural residential communities in the process of improvement of the environment and livelihoods of the local people in the MD.

5. References

- [1] Biogas program for the animal husbandry sector in Vietnam, 2011. Project overview (www.biogas.org.vn/english/Gioi-thieu-du-an.aspx, retrieved on 2011-10-15)
- [2] Biogas project division, 2008. Biogas mason training manual. Biogas Programme for the Animal Husbandry Sector in some Provinces of Vietnam. Vietnam (in Vietnamese)
- [3] Biogas project division, 2006. BP I final report. Biogas Programme for the Animal Husbandry Sector in some Provinces of Vietnam. Vietnam
- [4] Botero, R., Preston, T. R. 1986. Low-cost biodigester for production of fuel and fertilizer from manure (spanish). Manuscript ineditado CIPAV, Cali, Colombia, pp 1-20
- [5] Bui, X. A., Ngo, V. M., Duong, N. K., Nguyen, D. A., Preston, T. R. 1994. Installation and performance of low-cost polyethylene tube biodigesters on small-scale farms in Vietnam. In: Proceedings of National Seminar-workshop on Sustainable Livestock Production on Local Feed Resources, edited by Preston, T. R. et al. Ho Chi Minh City, Viet Nam. November 1993.
- [6] Bui, X A., Preston, T. R., Dolberg, F. 1996. The introduction of low-cost plastic polyethylene tube biodigesters on small-scale farms in Vietnam (www.lrrd.org/lrrd9/2/an92.htm, retrieved on 2010-09-15)
- [7] CENREs - Centre of Environmental Engineering and Renewable Energies, 2002. Manual on TG-BP biogas plant construction. Can Tho University (in Vietnamese)
- [8] Do, K. T. 2005. Overview of Biogas Technology in Viet Nam (www.methanetomarkets.org/expo_chna07/docs/postexpo/agvietnam.pdf, retrieved on 2010-08-18)
- [9] Do, N. Q. 1989. Experience on organize and deploy the biogas plant at provinces in the Mekong Delta - The first step in Can Tho city. In: Biogas application in Vietnam, edited by Lam, M. T. et al. Proceeding on the first national workshop of the National Renewable Energy Programme 52C. Ho Chi Minh city, Vietnam. March 1989 (in Vietnamese)
- [10] Le, H. V. 2005a. Principles of wastewater treatment methods. Lecture note from Can Tho University, Vietnam (in Vietnamese)
- [11] Le, T. H. 2005b. Method to build an improved biogas plant in cheap way (<http://longdinh.com/default.asp?act=chitiet&ID=707&catID=2>, retrieved on 2010-07-19)
- [12] Le, T. T. 2010. Data on KT2 plant in the Mekong Delta. Biogas Project Division, Head of Technical Department
- [13] Le, T. X. T. 2008. Bio-slurry utilization in Vietnam. Report of Biogas Project Division. The Biogas Program for the Animal Husbandry Sector of Vietnam
- [14] MARD - Vietnam Ministry of Agriculture and Rural Development. 2002. Decision 21/2002/QĐ-BNN regarding the Vietnamese standards on environmental aspect (in Vietnamese)
- [15] Nguyen, G. L., Nguyen, Q. K. 2005. Development of biogas technology in Vietnam (<http://www.vcn.vnn.vn/PrintPreview.aspx?ID=2895>, retrieved on 2010-07-19) (in Vietnamese)
- [16] Nguyen, N. E., Do, N. Q. 2009. Introduction on biogas plant models EQ1 and EQ2. Presentation at the final workshop of VIE/020-Water hyacinth project (in Vietnamese)
- [17] Nguyen, Q. K. 1989. The fixed-dome biogas plant. In: Biogas application in Vietnam, edited by Lam, M. T. et al. Proceeding on the first national workshop of the National Renewable Energy Programme 52C. Ho Chi Minh city, Vietnam. March 1989 (in Vietnamese)
- [18] Nguyen, V. C. N. 2011. Small-scale anaerobic digesters in Vietnam - development and challenges. *J. Viet. Env.* 1(1):12-18
- [19] Pound, B., Bordas, F., Preston, T. R. 1981. Characteristics of production and function of a 15 cubic meter Red-Mud PVC biogas digester. *Tropical Anim. Prod.* 6: 146-153
- [20] SEDDC 2010. Sustainable Energy Development Consultancy Joint Stock Company. Evaluation study for household biogas plant models (www.snvworld.org/en/Documents/Evaluation_study_for_household_biogas_plant_models_Vietnam_2010.pdf, retrieved on 2011-10-18)
- [21] SEDDC 2011. Sustainable Energy Development

- Consultancy Joint Stock Company. Optimization of household composite biogas project (http://www.eepmekong.org/_downloads/2-V-010_SEDDC.pdf, retrieved on 2011-10-18)
- [22] Biogas Technology Center 2011. Introduction of the Biogas Technology Center - Chiang Mai University, Thailand (<http://grove.ufl.edu/~bests/pdfs/050606%20Chuckree%20Senthong.pdf>, retrieved on 2011-10-18)
- [23] Tran, V. D., Ha, V. H., Huynh, T. L. H. 2009. Biogas user survey 2007 ÷ 2008. Biogas development programme for livestock sector in Vietnam
- [24] Vo, H. N. 2011. Results of application of the KT2 and composite biogas plants in Ca Mau. Presentation in the WATSAN Workshop of Report on testing results the KT2 and composite biogas plants. Ca Mau, August 26th 2011 (in Vietnamese)