



Complete Solutions for Your Power Needs



Global Experience

A leading supplier in mid-range industrial gas turbines and gas turbine-driven generator sets from 1 to 20 MW, Solar Turbines designs and manufactures rugged, reliable products using quality systems certified to ISO 9001 standards. Solar offers complete solutions - from engineering specification to asset management - for industrial power generation applications from 1 to 50 MW.

A wholly owned subsidiary of Caterpillar Inc., Solar Turbines Incorporated has a fleet of more than 11,200 gas turbine units--with over 1,000,000,000 operating hours--installed in 90 nations.

Solar's unrivalled level of experience and worldwide Customer Services network are among the key reasons why customers continue to make *Solar*[®] gas turbines and generator sets the first choice to meet their energy requirements in a variety of cogeneration, base-load, peak shaving, distributed power and standby duty applications such as:

Industrial/Processing Facilities

- chemicals
- pharmaceuticals
- foods and ingredients
- dairies and dairy products
- beverages
- breweries

- grain processors
- ceramics
- cement
- gypsum
- paper and paper products
- wood products
- plastics
- tires and rubber products
- refineries
- manufacturing

Buildings/Institutions

- district heating and cooling plants
- universities
- hospitals
- resorts and hotels
- commercial buildings
- telecommunications complexes
- computer centers

Distributed Power

- remote locales
- small utilities
- load management
- areas with rapid demand growth

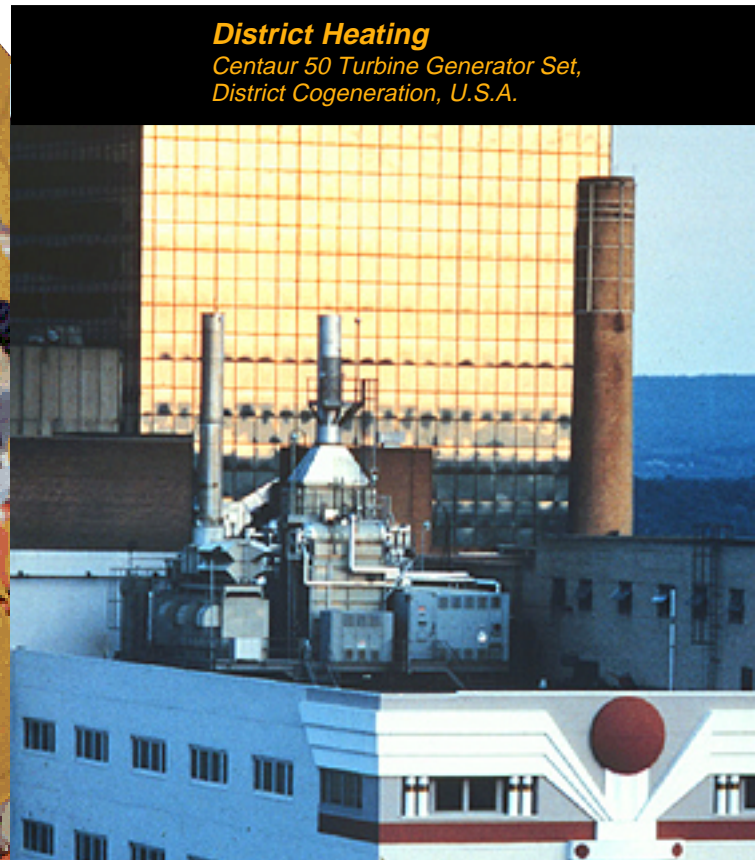

District Heating

*Centaur 50 Turbine Generator Set,
District Cogeneration, U.S.A.*

Single-Source Advantages

Solar Turbines designs and manufactures its gas turbines and turbine generator sets to ensure maximum systems compatibility and integration, plus high performance, reliability, availability, efficiency, and long life in the most demanding applications. As the customer's single source, Solar Turbines also can provide:

- engineering, procurement and construction (EPC) services, including turnkey
- commissioning
- technical training
- field service
- certified parts
- repairs, overhauls, upgrades
- complete project operation and maintenance
- contract power and leasing
- financing packages

SoLoNO_x Pollution Prevention

Solar gas turbines have low exhaust emissions levels and can meet virtually any current clean air standard with *SoLoNO_x* lean-premixed combustion technology.

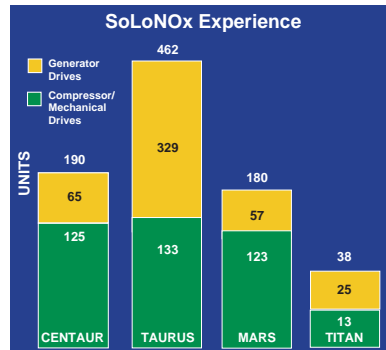

Outstanding Efficiency

Solar turbine generator sets are highly efficient simple-cycle units. When installed in combined cycle and combined heat and power applications, the efficiency is further enhanced. For example, in energy-saving cogeneration applications, overall system thermal efficiencies of 70-80% are common.

The gas turbine's clean, dry, oxygen-rich exhaust stream can be:

- used as a hot-air source for many drying applications
- ducted to an unfired heat recovery steam generator (HRSG)
- used as preheated combustion air for supplementary-fired HRSGs to produce high volumes of process steam
- used for direct heating in absorption chillers that provide chilled water

Multi-Fuel Capability

Solar gas turbines operate on a wide variety of fuels:

- natural gas
- distillates
- natural gas liquids (NGLs)
- liquefied petroleum gases (LPGs)
- hydrogen
- medium-Btu gas (coal-bed methane, landfill gas)

Dual and tri-fuel systems can be configured for use with many models of *Solar* gas turbines.

Fast Delivery

Modern, efficient manufacturing facilities and processes and skilled personnel enable Solar to quickly provided generator sets engineered and tested to fulfill specific customer requirements.

Institutional Cogeneration

Taurus 60 Turbine Generator Set, Hospital Cogeneration, U.S.A.



Industrial Cogeneration

Taurus 60 Turbine Generator Set, Industrial Process, Thailand



Solar Gas Turbine Generator Sets

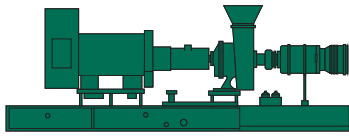

Saturn 20 Generator Set

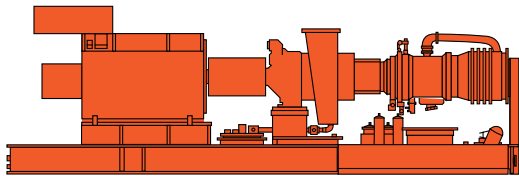

Centaur 40 and Centaur 50 Generator Sets

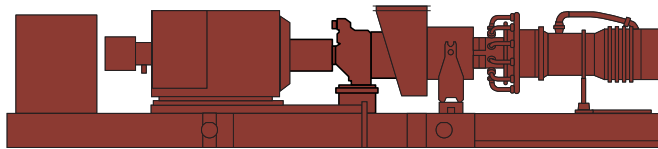

Taurus 60 and Taurus 70 Generator Sets

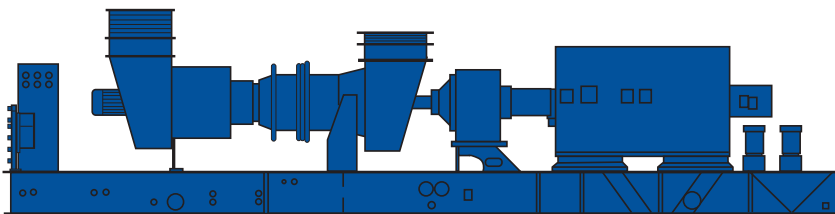

Mars 90 and Mars 100 Generator Sets

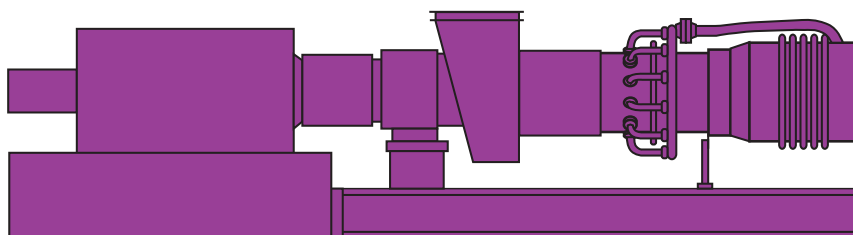

Titan 130 Generator Set



Industrial Cogeneration
*Taurus 60 Turbine Generator Set,
Food Processing, Canada*



Peaking Power
*Taurus 60 Turbine Generator Sets,
Rural Electric Coop, U.S.A*

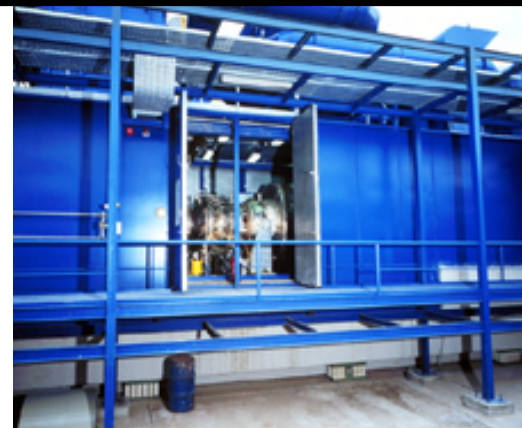

Institutional Cogeneration
*Mars 100 Turbine Generator Set, Tri-Fuel
Paper Plant, Turkey*



Distributed Power

Two Mars 100 Turbine Generator Sets,
Combined-Cycle Utility Power, Australia



District Heating/Cooling

Taurus 60 Turbine Generator Set
STAC Unit, U.S.A.



Mobile Peaking Power

Four Taurus 60 Turbine Generator Sets,
Refinery, U.S.A.

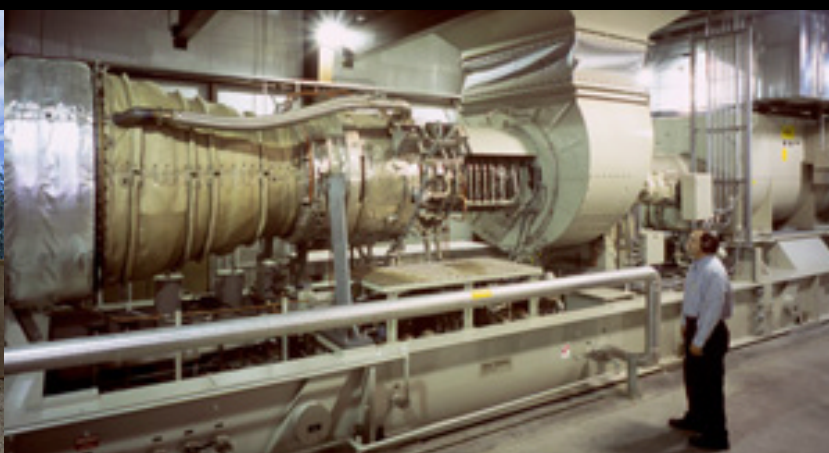

Peaking Power

Three Titan 130 Turbine Generator Sets
Municipal Power, U.S.A.



District Heating

Centaur 50 Turbine Dual-Fuel, SoLoNO_x
Cogeneration/District Heating, Germany



Industrial Cogeneration

Mars 100 Turbine Generator Set,
Heat Recovery, Paper Mill, U.S.A.

Generator Set Performance

The following curves provide performance data for each continuous-duty *Solar* gas turbine generator set at full load under standard conditions

(sea level, natural gas fuel, 60% relative humidity, zero inlet and exhaust losses). Power and efficiency ratings are nominal at the generator

terminals. For detailed performance data, please contact the Solar Turbines sales office nearest you.

Titan™ 130 Generator Set Performance

ISO Continuous Duty Output	Heat Rate	Exhaust Flow	Exhaust Temperature
14 000 kWe	10 465 kJ/kW-hr 9 920 Btu/kW-hr	179 060 kg/hr 490 °C 394,750 lb/hr 920 °F	

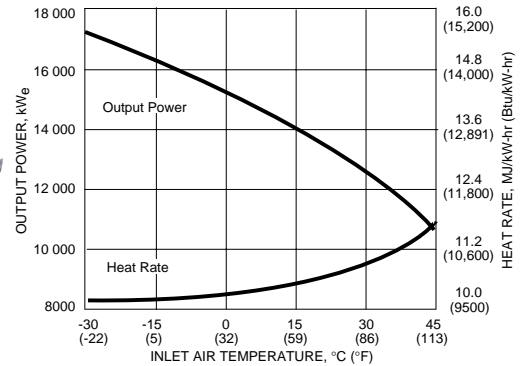
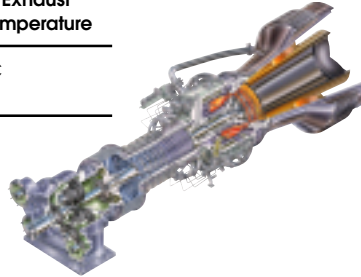

Mars® 100 Generator Set Performance

ISO Continuous Duty Output	Heat Rate	Exhaust Flow	Exhaust Temperature
10 690 kWe	11 090 kJ/kW-hr 10,520 Btu/kW-hr	150 390 kg/hr 331,550 lb/hr	485 °C 910 °F

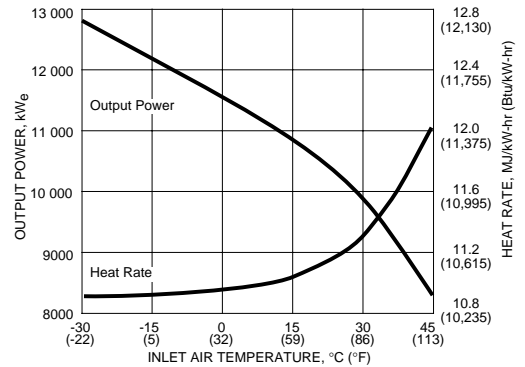
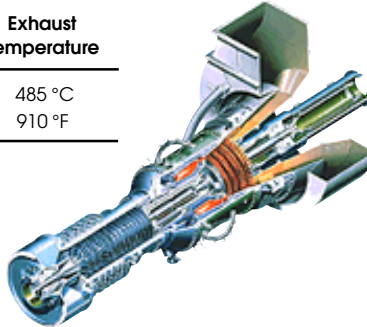

Mars 90 Generator Set Performance

ISO Continuous Duty Output	Heat Rate	Exhaust Flow	Exhaust Temperature
9450 kWe	11 300 kJ/kW-hr 10,710 Btu/kW-hr	144 590 kg/hr 318,760 lb/hr	470 °C 870 °F

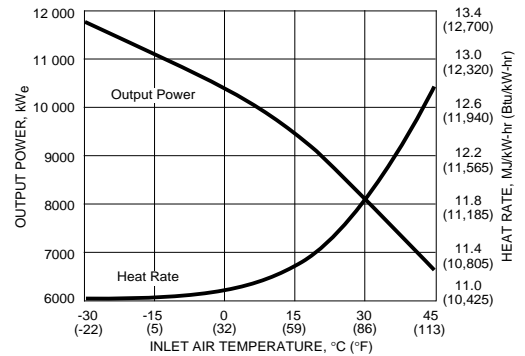
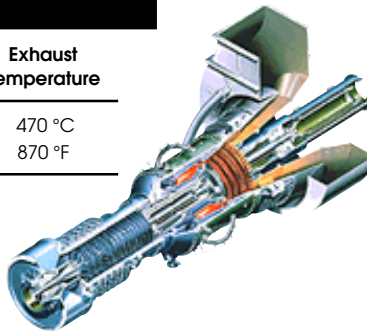

Taurus™ 70 Generator Set Performance

ISO Continuous Duty Output	Heat Rate	Exhaust Flow	Exhaust Temperature
7520 kWe	10 650 kJ/kW-hr 10,100 Btu/kW-hr	97 000 kg/hr 213,840 lb/hr	490 °C 910 °F

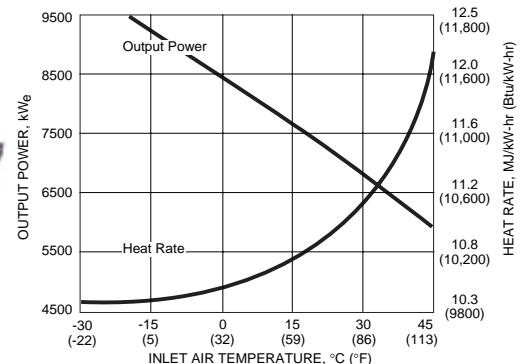
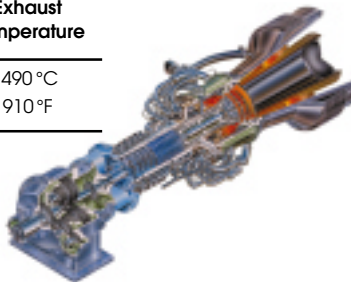

Taurus 60 Generator Set Performance

ISO Continuous Duty Output	Heat Rate	Exhaust Flow	Exhaust Temperature
5500 kWe	11 840 kJ/kW-hr 11,225 Btu/kW-hr	78 820 kg/hr 173,770 lb/hr	510 °C 950 °F

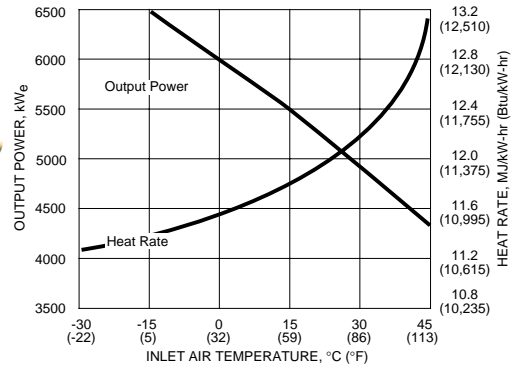
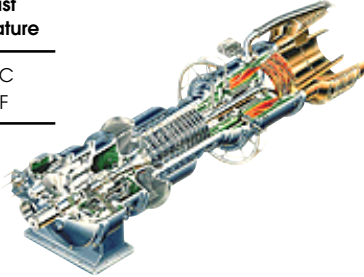

Centaur® 50 Generator Set Performance

ISO Continuous Duty Output	Heat Rate	Exhaust Flow	Exhaust Temperature
4600 kWe	12 270 kJ/kW-hr 11,630 Btu/kW-hr	68 680 kg/hr 151,410 lb/hr	510 °C 950 °F

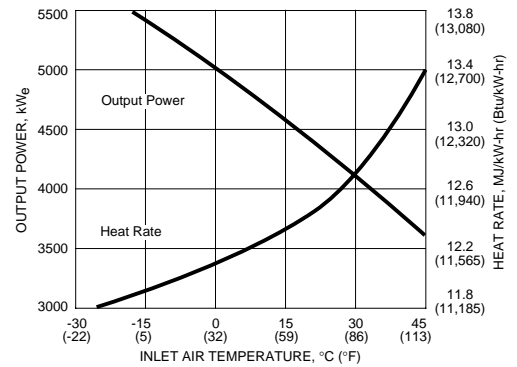
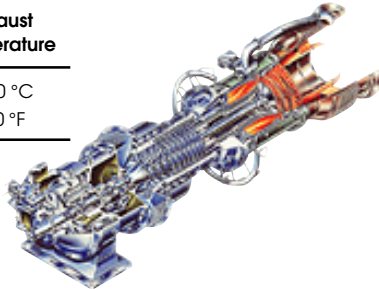

Centaur 40 Generator Set Performance

ISO Continuous Duty Output	Heat Rate	Exhaust Flow	Exhaust Temperature
3515 kWe	12 910 kJ/kW-hr 12,240 Btu/kW-hr	67 000 kg/hr 147,720 lb/hr	435 °C 820 °F

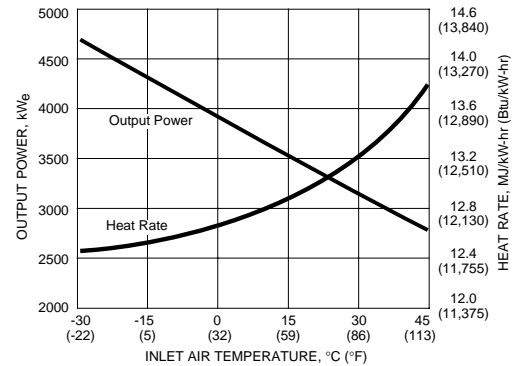
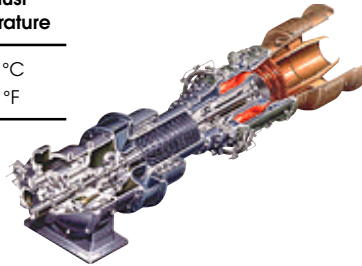

Saturn® 20 Generator Set Performance

ISO Continuous Duty Output	Heat Rate	Exhaust Flow	Exhaust Temperature
1210 kWe	14 795 kJ/kW-hr 14,025 Btu/kW-hr	23 540 kg/hr 51,900 lb/hr	505 °C 940 °F

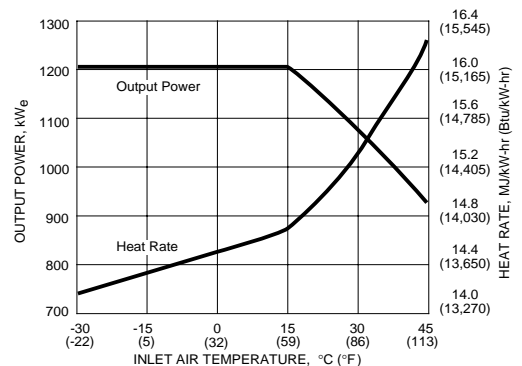
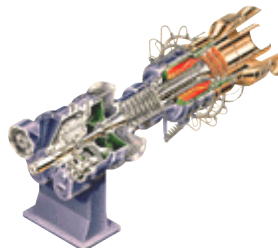

Basic Package Features

Industrial Gas Turbine

- rugged design
- high availability
- high reliability
- long life
- low maintenance
- extended overhaul intervals

Main Gearbox

- epicyclic speed-reduction gearing

Generators

- 50 Hz standard voltages
- 60 Hz standard voltages

Governor

- isochronous mode
- droop mode
(automatic load-sharing with similar units in isochronous mode is standard)

Starting

- electric starting system standard
- black-start systems available

Lubrication System

- pumps
- reservoir
- filters
- low-pressure protection
- high-temperature protection
- air-to-oil or water-to-oil cooler

Turbotronic™ Control System

- sequences starting and shutdown
- monitors/protects during operation
- microprocessor-based
- powerful with high reliability
- remote operation available

Modifications

- standard factory modifications available to customize units to specific applications

Approximate Package Dimensions and Weights[#]

Generator Set Designation	Length, m (ft-in.)	Width, m (ft-in.)	Height, m (ft-in.)	Wet Weight, kg (lb)
Titan 130	14.0 (46' 0")	3.3 (10' 10")	3.3 (10' 9")	74 390 (164,000)
Mars 100	14.5 (47' 6")	2.8 (9' 2")	3.6 (12' 0")	73 028 (161,000)
Mars 90	14.5 (47' 6")	2.8 (9' 2")	3.6 (12' 0")	64 698 (142,500)
Taurus 70	10.4 (34' 0")	2.8 (9' 2")	3.3 (10' 9")	45 670 (100,703)
Taurus 60	9.8 (32' 0")	2.5 (8' 2")	2.9 (9' 8")	32 808 (72,342)
Centaur 50	9.8 (32' 0")	2.5 (8' 2")	2.9 (9' 8")	32 699 (72,102)
Centaur 40	9.8 (32' 0")	2.5 (8' 2")	2.9 (9' 8")	32,631 (71,952)
Saturn 20	5.8 (18' 11")	1.7 (5' 5")	2.0 (6' 6-1/2")	9980 (22,000)

[#] Actual values vary with customer options specified, such as type of generator.

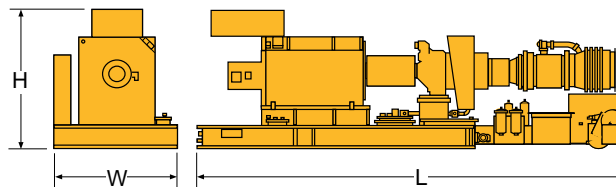

Enclosures (optional)

- outdoor weather-resistant
- sound attenuated
- fire/gas detection/suppression

Ancillary Systems

A wide variety of ancillary equipment is available to meet all installation needs:

- silencers
- filters
- ducting

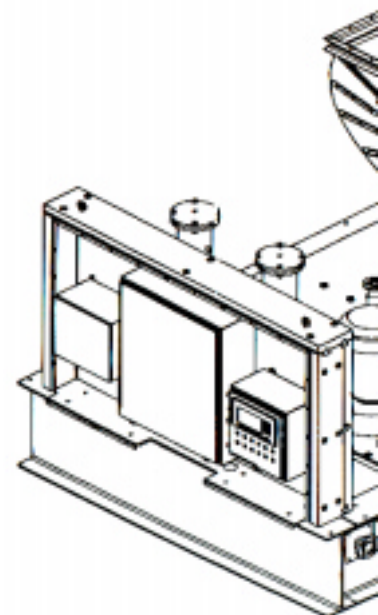

Gas Turbine

EXHAUST COLLECTOR

TURBINE ASSEMBLY

COMBUSTOR

COMPRESSOR

AIR INLET

Gearbox

Generator

**Microprocessor-
Based Controls**

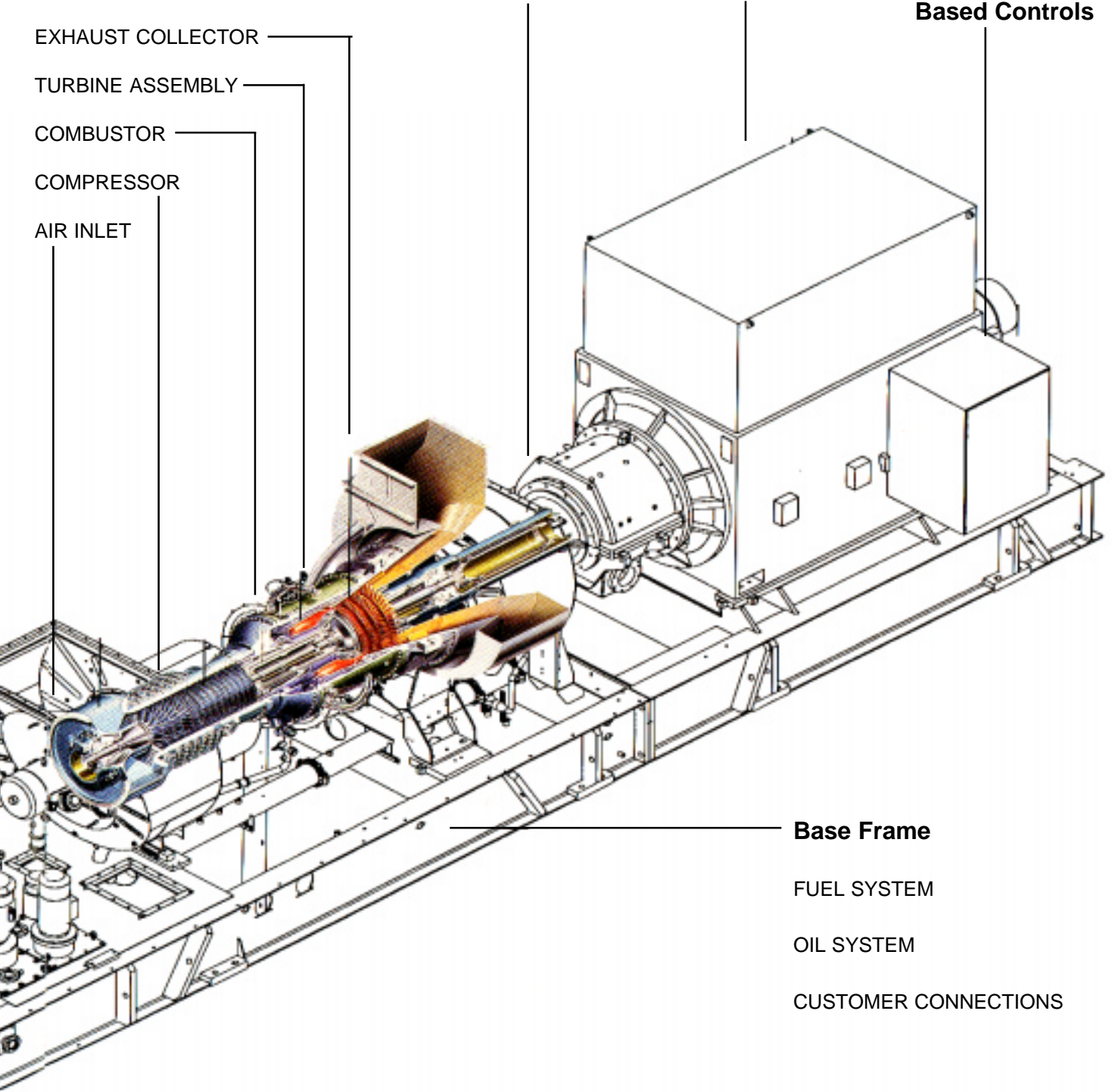

Base Frame

FUEL SYSTEM

OIL SYSTEM

CUSTOMER CONNECTIONS

Product Development

Collaborating closely as members of cross-functional teams, Solar's employees work to develop new technologies and products to meet anticipated as well as current customer requirements. Solar's historic backbone, the technical staff, continues to advance the company's technical leadership with such innovations as:

- pollution-prevention, dry low emissions *SoLoNO_x* combustion
- advanced, energy-saving primary surface gas turbine recuperators

- fourth-generation microprocessor-based control systems
 - gas turbines in new size ranges
 - ceramic gas turbine components
 - advanced gas turbine systems for the 21st century
- Employee efforts in these areas are vital elements of Solar's commitment to uncompromising quality and continuous improvement.

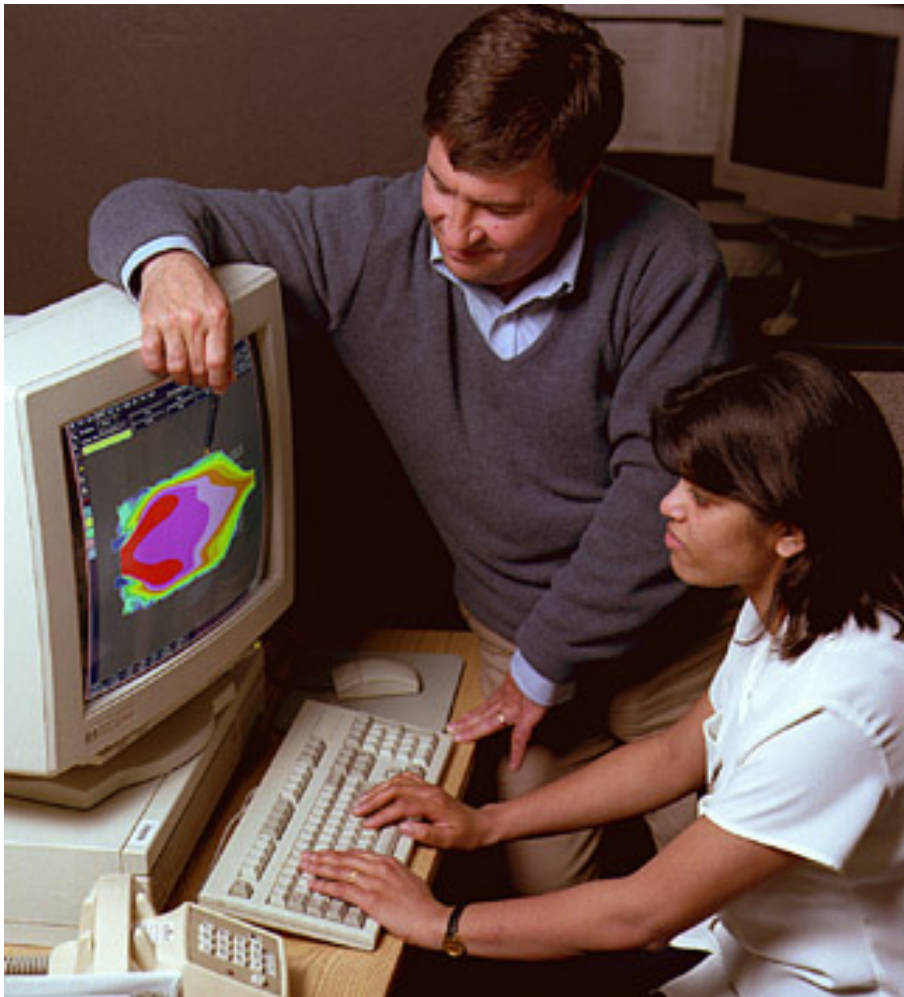
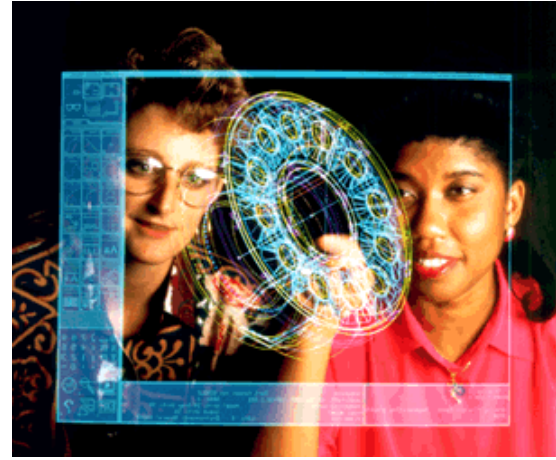

Worldwide Support Services



Construction Services

- engineering
- procurement
- construction
- installation

Customer Services

Solar is committed to providing our customers with the lowest possible life-cycle costs for their turbomachinery projects as well as comprehensive support services through our global network of overhaul centers, parts depots, field service offices and training facilities.

Field Service

- 37 strategic locations worldwide
- around-the-clock response
- ready access to Solar's full technical, research, engineering, and manufacturing resources

Certified Parts

- genuine *Solar* turbine service parts stocked at depots worldwide
- rapid order processing and shipment

Overhauls

- gas turbine overhaul and repair centers in Europe, Canada, Asia, Mexico, Nigeria, Australia, and U.S.A.
- exchange engine program to minimize downtime

Technical Training

- expert training of customer personnel at field sites or Solar's facilities

Extended Service Agreements

- extended warranty covering all engine and package components
- exchange engines
- fixed-cost maintenance

Asset Management Services

- full-service plant operation and maintenance for customer installations worldwide



Solar[®] Turbines

A Caterpillar Company

Solar has been a pioneer in the design, manufacture and packaging of gas turbine systems for more than 50 years and is a world leader in the mid-range industrial gas turbine business. So, customers in 90 nations spanning the globe know they can rely on Solar Turbines to provide rugged, reliable turbomachinery systems, responsive service, technical assistance and service parts availability with a worldwide, around-the-clock support network.



Solar Turbines Headquarters
San Diego, California

For More Information

For more information on Solar gas turbine generator sets, please contact:

Solar Turbines Incorporated
Dept. BIPG
P.O. Box 85376
San Diego, CA 92186-5376, U.S.A.
Telephone: (+1) 619-544-5352
Telefax: (+1) 858-694-6715
Internet: www.solarturbines.com

or your nearest Solar sales office.

U.S. Sales Offices:
Anaheim, CA;
Anchorage, AK;
Chicago (Naperville), IL;
Dallas (DeSoto), TX;
Houston, TX;
Miami, FL;
New Orleans, LA;
New York City
(Upper Saddle River, NJ);
Salt Lake City, UT;
and Washington, DC.

Outside the U.S., please contact:

Solar Turbines Europe S.A.:
Brussels (Gosselies), Belgium;
London (Slough, Berkshire), U.K.,
and Dubai, UAE

Caterpillar Overseas S.A.
Moscow, Russia

Caterpillar China, Ltd.
Beijing, Peoples Republic of China

Solar Turbines Asia
New Delhi, India; Singapore,
Republic of Singapore; and
Tokyo, Japan

Solar Turbines Australia
Melbourne (Rowville), Victoria

Solar Turbines Canada Ltd.
Calgary, Alberta

Turbinas Solar, S.A. de C.V.
Mexico City, Mexico

Delcom Services SDN BHD
Kuala Lumpur, Malaysia

P.T. Indoturbine
Jakarta, Indonesia